

Your property guardian at day and night

netvue

Vigil Camera Quick Guide

Warning

FCC

This device complies with part 15 of the FCC Rules. Operation is subject to the condition that this device does not cause harmful interference (1) this device may not cause harmful interference, and (2) this device must accept any interference received, including interference that may cause undesired operation.

Any changes or modifications not expressly approved by the party responsible for compliance could void the user's authority to operate the equipment.

NOTE: This equipment has been tested and found to comply with the limits for a Class B digital device, pursuant to Part 15 of the FCC Rules. These limits are designed to provide reasonable protection against harmful interference in a residential installation. This equipment generates, uses and can radiate radio frequency energy and, if not installed and used in accordance with the instructions, may cause harmful interference to radio communications. However, there is no guarantee that interference will not occur in a particular installation.

If this equipment does cause harmful interference to radio or television reception, which can be determined by turning the equipment off and on, the user is encouraged to try to correct the interference by one or more of the following measures:

- Reorient or relocate the receiving antenna.
- Increase the separation between the equipment and receiver.
- Connect the equipment into an outlet on a circuit different from that to which the receiver is connected.
- Consult the dealer or an experienced radio/TV technician for help.

The device has been evaluated to meet general RF exposure requirement. The device can be used in portable exposure condition without restriction.

The antennas used for this transmitter must be installed to provide a separation distance of at least 20 cm from all persons and must not be co-located for operating in conjunction with any other antenna or transmitter.

FCC ID 2A08RNI-1900

CE RED

This product can be used across EU member states.

What's In The Box

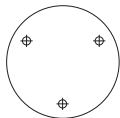

Drilling Template

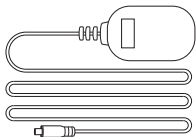

Power Adapter



Quick Guide



Hex Key



Mounting Screws X 3



Anchors X 3



Drill Bit



Weatherproof Tube



Antenna

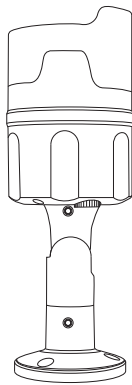

Vigil Camera

Installation Guide Catalogue

- | | |
|------------------------------|----------|
| 1. More About Vigil Camera | P. 1-2 |
| 2. Read Before Installing | P. 3 |
| 3. Set Up with Netvue App | P. 4-12 |
| 4. Vigil Camera Installation | P. 13-20 |
| 5. Status Light | P. 21 |

More about Vigil Camera

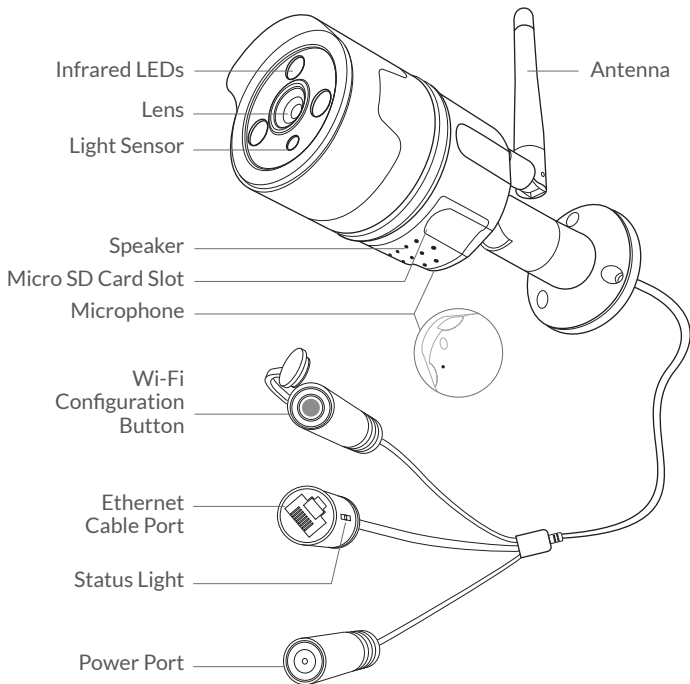

How to Insert Micro SD Card

Vigil Camera comes with a built-in card slot which supports up to 128GB Micro SD card. Once you insert the storage card, the camera will automatically start to record and store videos on the storage card. You can view those videos in the 'Replay' page by clicking the 'Replay' button  in the 'Homepage'.

Step 1: Loosen the screws. Take off the cover gently since wires are attaching to it.

Step 2: Insert Micro SD card. Make sure you insert it in the correct direction. The back of the card should face up.

Step 3: Put the cover back and tighten the screws.

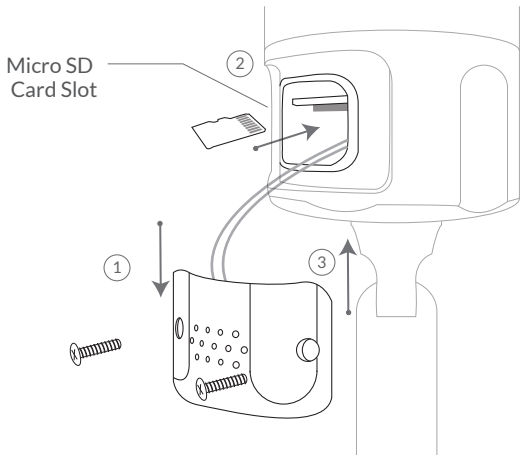

Read Before Installing

1. Keep the Vigil Camera and all accessories out of reach of children and pets.
2. Power supply voltage that is required to operate Vigil Camera should be DC12V ($\geq 1000\text{mA}$).
3. The product can only be used in proper temperature and humidity:
Operating temperature: $-10^{\circ}\text{C} - 50^{\circ}\text{C}$ ($14^{\circ}\text{F} - 122^{\circ}\text{F}$)
Operating humidity: 0-95%.
4. Please do not expose the camera lens to direct sunlight.
5. Please do not install the camera to the place that is likely struck by lightning.

Set Up with Netvue App

Please add the Vigil Camera onto your Netvue account through Netvue App before mounting it outside.

Connecting Method

There are two ways of adding Vigil Camera onto Netvue App: Wireless Connection and Wired Connection.

Wireless connection

Wireless connection uses Wi-Fi to connect the camera to the App. It is the easiest way if the installation spot is close to your router and have a strong Wi-Fi signal. Please note that thick or insulated wall may weaken the signal dramatically. Before you decide to choose this connection method, check the Wi-Fi signal at your installation spot.

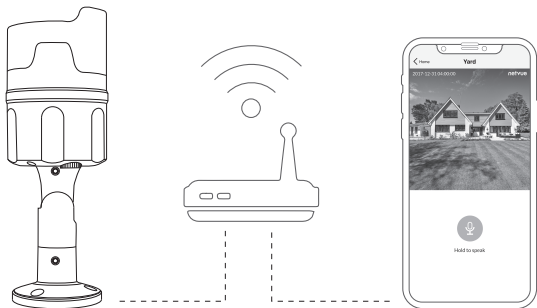

Wired connection

If the Wi-Fi signal strength is weak at your installation spot, the Ethernet cable connection might be your solution. An Ethernet cable is required for this connection method. Plug one end of the Ethernet cable into Vigil Cam, and the other end into the LAN port on your router. Then follow the in-app instruction to complete the following set up process.

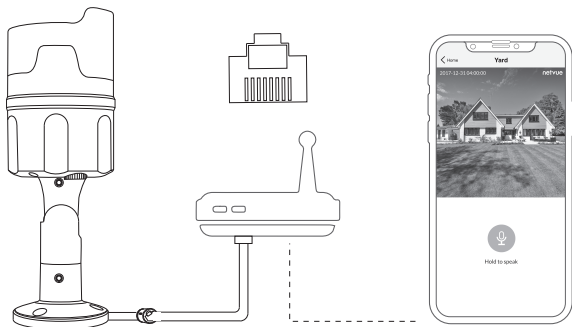

Add Camera to Netvue App



Download Netvue App



1. Download Netvue App from App Store or Google Play onto your phone.



2. Register an account if you are a new user to Netvue. If you already have an account, log into your account.

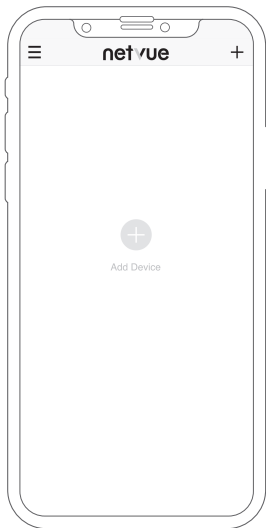

3. Tap “+” to add a new device.

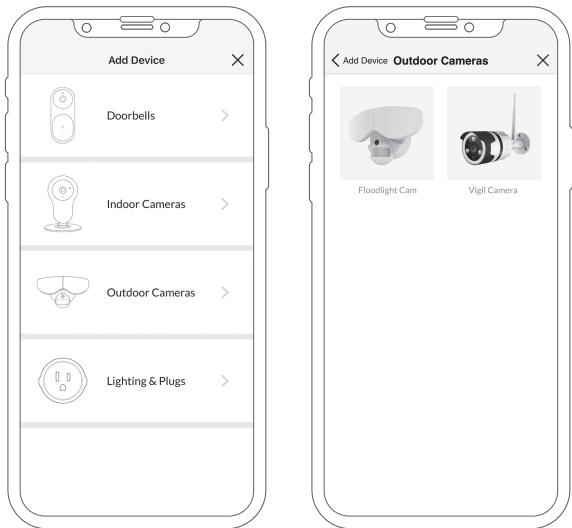

4. A product list will show up. Choose 'Outdoor Cameras' - 'Vigil Camera'.

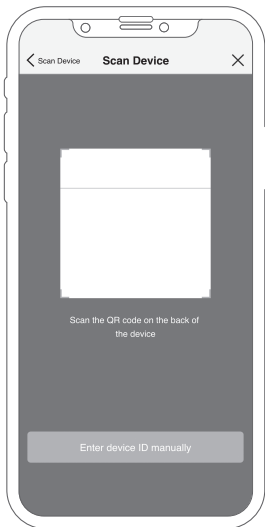

5. Scan the QR code on the back of the Vigil.

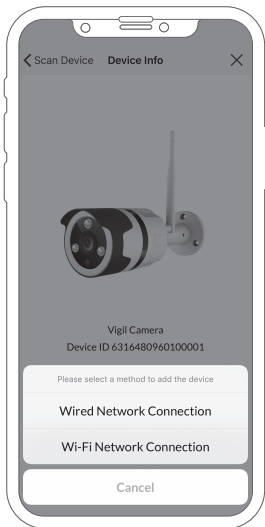

6. Choose a connecting method, and then follow the in-app instruction to complete the entire set up process.

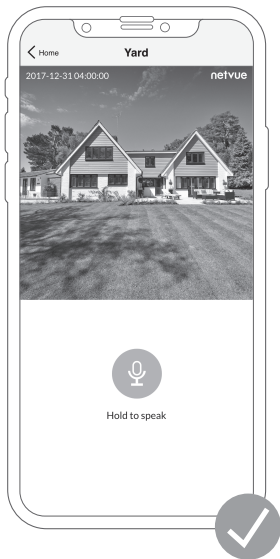

7. Test the video streaming.
Now move to Vigil Camera installation.

Vigil Camera Installation

Check following things before you starting to drill holes on your wall:

1. Vigil Camera has been successfully added to your Netvue App and is able to stream video.
2. Have planned the cable route. Measured the length of the power cable and Ethernet cable (if you plan to use Ethernet connection) you will need.

Step 1:

Take off the anti-dust cap. Attach the provided antenna to Vigil Camera.

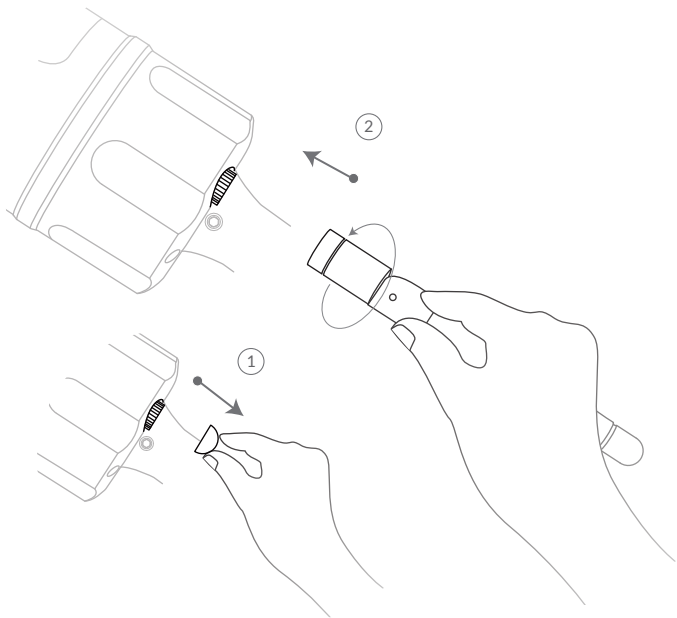

Step 2:

Find a good installation spot.

- We recommend installing the Vigil camera just 7-10 feet (2-3 meter) above the ground for a better two-way audio experience.
- There is a power outlet nearby.
- Test whether Vigil camera can stream video smoothly at the spot.
- Make sure nothing blocks the camera's sight.

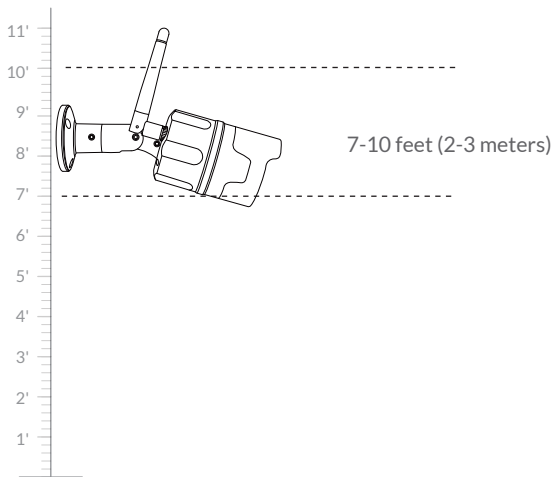

Step 3:

Before you starting to drill, make sure you know the locations of wall-in pipes and electrical wires. (If you are not comfortable with drilling holes, please consult with a licensed electrician.)

Install Camera on Concrete or Brick:

Use the provided drilling template to mark the position of holes on your wall. Use the provided drill bit to drill three holes, and then install anchors to hold screws.

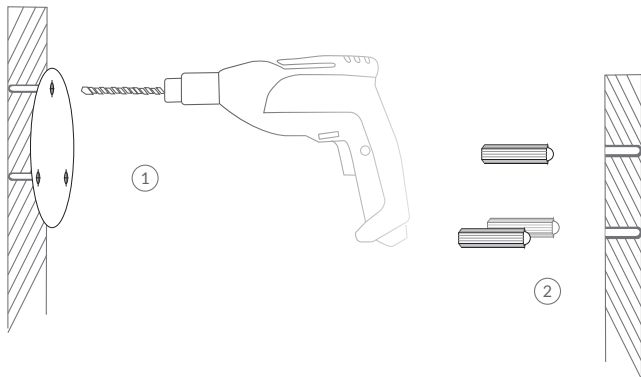

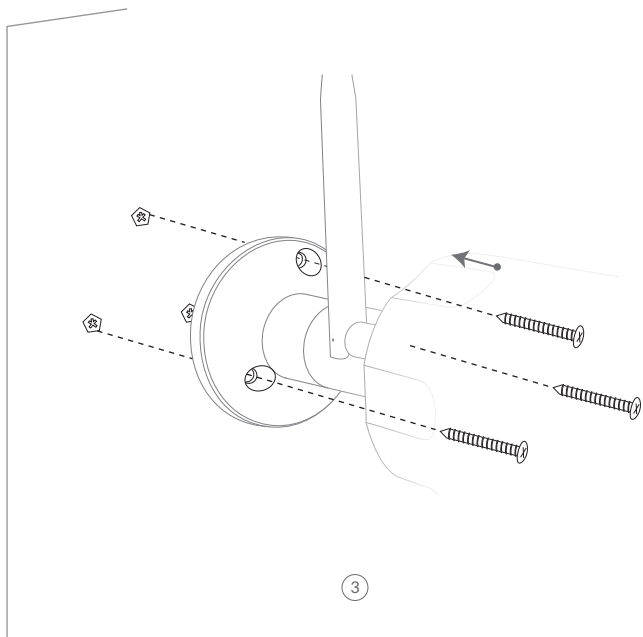

Install Camera on Wood:

Use the provided drilling template to mark the position of holes on wood.
Directly tighten the included screws to secure the camera.

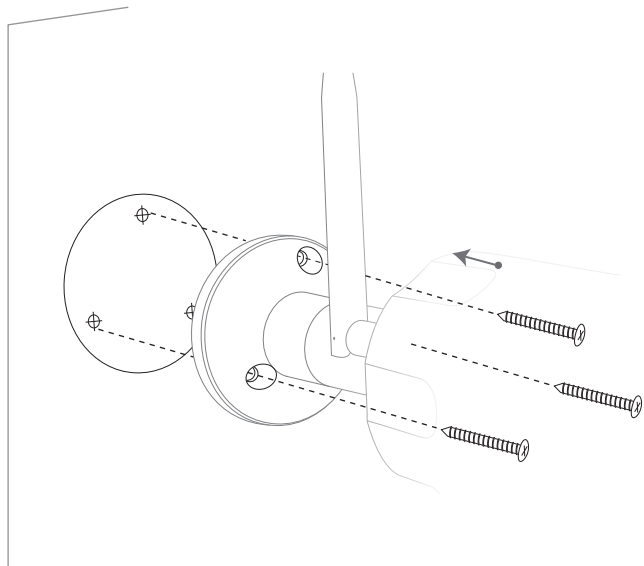

Step 4 (Wired Connection):

Read this step if you are using wired connection, otherwise skip to Step 5. This step requires the skill of making an Ethernet cable. Consult with the electrician if you are not sure how to do it.

A weatherproof tube is needed for Ethernet cable to avoid leaking water into Ethernet cable port. Cut off the Ethernet cable at the length you want. Insert the cable into the weatherproof tube, and carefully attach RJ-45 connector to the cut ends. Test the cable is working before installing.

Things you need:

Bare copper Ethernet cable

RJ45 connector

RJ45 crimping tool

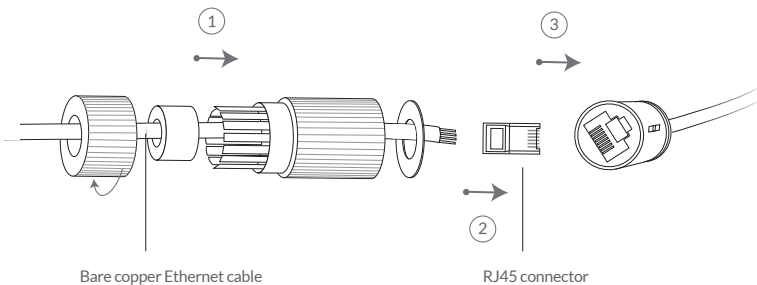

Step 5:

Use the hex key to loosen screws on the hinge. Point the camera to your designate direction, then tighten the screws.

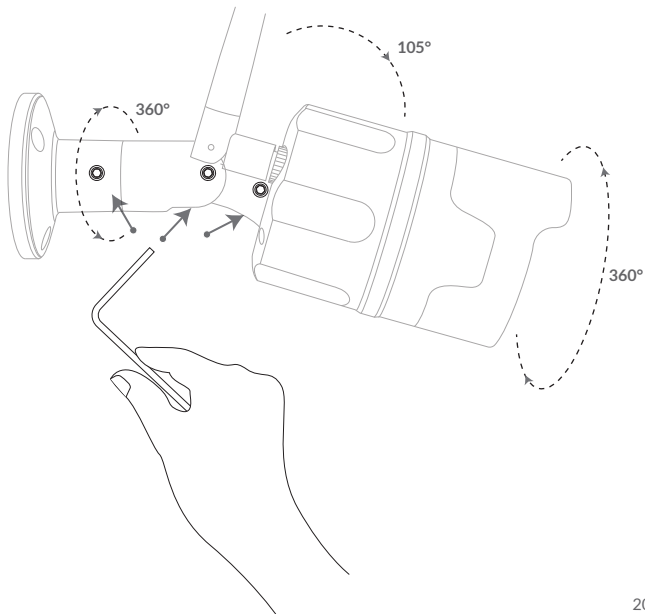

Status Light

Netvue Vigil Camera uses status light to communicate.

Status Light	Description
Solid Green	Online
Blinking Green	Wi-Fi Configuration Mode
Slowly Blinking Green	Offline
None	Not Working Properly

netvue

Feel free to contact us for additional help:



support@netvue.com



1(866)749-0567



[@NetvueTech](https://www.facebook.com/NetvueTech)



Netvue Forum
netvue.com/community



in-App Chat

www.netvue.com

240 W Whitter Blvd Ste A, La Habra, CA 90631

© 2010-2019 Netvue Technologies Co., Ltd. All Rights Reserved.

Version 1.2